

## Numerical simulation of the forming processes accounting for asymmetry of elastic range and initial anisotropy

Marcin Nowak, Jerzy Luckner, Zdzisław Nowak and Ryszard Pęcherski \*

Department of Mechanics of Materials, Institute of Fundamental Technological Research, Polish Academy of Sciences  
Pawińskiego 5B, 02--106 Warsaw, Poland

e-mail: nowakm@ippt.gov.pl, luckner@ippt.gov.pl, znowak@ippt.gov.pl, rpecher@ippt.gov.pl

### Abstract

The aim of the paper is to propose a new approach to the material description using the concept of so called corrected yield surface. The correction takes into account the deviation of determined experimentally yield surface from classical Huber-Mises yield condition for isotropic material. The formula for corrected yield surface is used as a plastic potential applied in the plastic flow law. It is shown that the proposed approach provides the satisfactory prediction of material behaviour, at least in the cases when the anisotropy effects are not so advanced.

*Keywords: anisotropic behaviour of metal sheets, asymmetry of elastic range, metal forming processes, finite element method*

### 1. Introduction

Finite element method is an efficient numerical tool to analyse such problems of shell deformation as for instance the sheet metal forming processes including cup drawing and stamping. Proper description of material properties is crucial for accurate analysis. In particular, the anisotropy and asymmetry of elastic range of considered materials play an important role in the finite element simulation. For metal forming analysis many experimental tests are needed to obtain the proper description of anisotropic behaviour of metal sheets. There are some attempts to account for both, anisotropy and the elastic range asymmetry, e.g. [1], [2]. However, according to our opinion, there is still lack of workable description of these effects, which could allow analysing effectively practical problems.

### 2. Problem formulation

The aim of the paper is to propose a new approach to the material description using the concept of so-called corrected yield surface, [3]. In case of plane stress yield surface is in the following form:

$$f = \sigma_1^2 + \sigma_3^2 - 2\lambda\sigma_1\sigma_3 + (k_c - k_r)(\sigma_1 + \sigma_3) - k_c k_r \quad (1)$$

where  $k_c$ ,  $k_r$  are initial yield stress for compression and tension and  $\lambda$  is anisotropy coefficient. The correction takes into account the deviation of determined experimentally yield surface from classical Huber-Mises yield condition for isotropic material. The formula for corrected yield surface is used as a plastic potential applied in the plastic flow law. It is shown that the proposed approach provides the satisfactory prediction of material behaviour, at least in the cases when the anisotropy effects are not so advanced.

Our material is described by Perzyna elasto-viscoplasticity model. The flow rule has the form:

$$\dot{\epsilon}_{ij}^{vp} = \gamma \left( \frac{f}{k_c k_r} \right)^p \frac{\partial f}{\partial \sigma_{ij}} \quad (2)$$

where  $\gamma$  and  $p$  are material parameters.

The return mapping algorithm was applied by numerical scheme formulation of the integration of elasto-viscoplasticity equations. The problem of the cup drawing of low carbon steel sheet is studied to simulate the Erichsen formability test.

### 3. Numerical simulation

Numerical simulation was performed with application of ABAQUS finite element program. The own VUMAT was implemented for calculations.

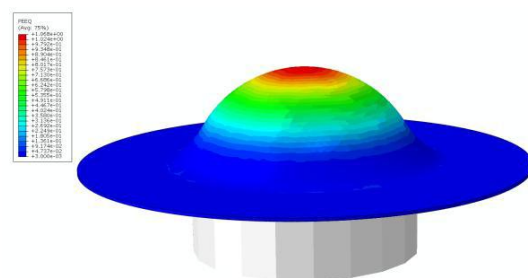

Fig. 1: The geometry and finite element mesh of sheet metal forming processes.



Fig. 2: The experimentally deformed shape of sheet metal

\* The research reported in the paper was partly obtained in the framework of the research project NUMPRESS carried out in IPPT PAN (Poland), co-funded by European Regional Development Fund grant nr: POIG.01.03.01-14-209/09 and the research project NN 501 12 15 36 of the Ministry of Science and High Education of Poland.

#### 4. Experimental identification of material model

The elasto-viscoplasticity model used in numerical calculations needs identification of material parameters. The same material - low carbon steel - as used in the formability test is applied in the identification procedure of constitutive model. Besides the elastic constants also the yield limits in the tensile test for the samples cut out along the rolling direction, perpendicular to rolling direction and under the angle of 45 (degree) are determined. Furthermore, the simple shear tests for the samples cut out from the metal sheet in the similar way were performed. An illustration of the sample, as well as, the shear device constructed by W.K. Nowacki [4] are presented in Fig. 3 and Fig. 4. The scheme of the specimen used in double shear tests is shown in Fig.4. A new shear device was used by Nowacki [4] to perform tests under high strain rates on specimens having the form of metal sheets. The loading and the displacements of this device are controlled by the split Hopkinson pressure bar (SHPB) acting in compression. The role of the special device is to transform the compression into a plane shear. The shear device for investigations at high strain rates as well as in quasi-static conditions consists of two coaxial cylindrical parts: the external tubular part and the internal massive part (see Fig. 4). Both cylinders are divided into two symmetrical parts, and between them the sheet to be tested is fixed.

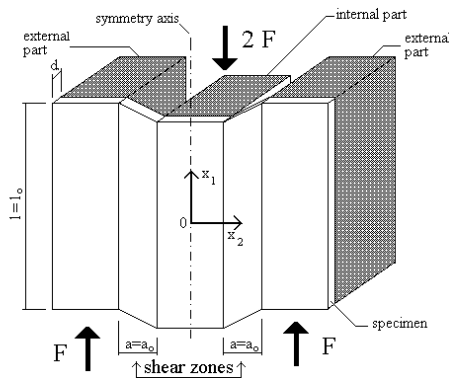

Fig. 3. The scheme of shear device constructed by W.K. Nowacki [4].



Fig. 4. The shear device for investigations at high strain rates as well as in quasi-static conditions.

The highest strain rate in the specimen was obtained with application of one bar of the SHPB system. In this experimental technique the flat projectile strikes directly the double shear specimen placed in the device in front of the transmitting bar. The details of the proper dimensioning the specimen are given in [4]. In our case, the material sheet has a nominal thickness of 0.64mm. In the case of dynamic test at high strain rates the specimens of the strain gauge length 20mm were used [4]. Design of the specimen for dynamic testing in simple shear is presented in Fig. 4.

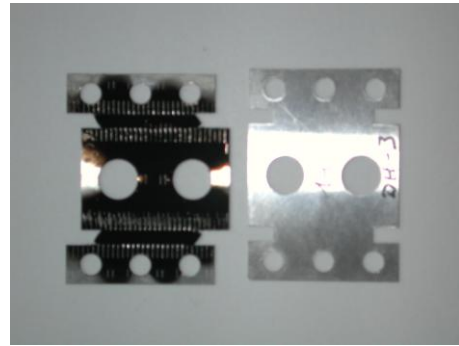

Fig. 5. Scheme of the specimen used in double shear tests.

The identification of the constitutive models parameters is obtained by an inverse method. The identification of these constants is carried out by the means of the true stress-strain diagrams. These curves are generated from the experimental tests performed at various strain rates. The elasto-viscoplastic model parameters are determined for each kind of specimen. In each case we have started our computations assuming at the beginning a broad range of feasible parameters. We assume some values of our parameters and we start calculations. After initialising and after final determination of material constants we apply our model in numerical simulation and we have obtain final reaction force and displacement.

Now, we can compare our model response with experimental observations.

#### References

- [1] B. Plunkett, O. Cazacu, F. Barlat, Orthotropic yield criteria for description of the anisotropy in tension and compression of sheet metals, *International Journal of Plasticity*, **22**, 1171–1194, 2006.
- [2] O. Cazacu, B. Plunkett, F. Barlat, Orthotropic yield criterion for hexagonal closed packed metals, *International Journal of Plasticity*, **24** 847–866, 2008.
- [3] Dietrich L., Grzywna P., Fraś T., Rusinek A., Pęcherski R.B., Application of the Burzyński's correction in determining the yield condition for the OFHC copper with initial anisotropy, *Archive of Metallurgy and Materials*, 2011-submitted for publication.
- [4] Nowacki W.K. Dynamic simple shear of sheets at high strain rates, in *Impact Engineering and Application*, Proc. of 4<sup>th</sup> International Symposium on Impact Engineering, (2001) Elsevier, 83-90.