

# Substructure-level based method for damage quantification in determinant trusses

**B. Blachowski<sup>1</sup>, Y. An<sup>2</sup>, B.F. Spencer<sup>3</sup> Jr.**

<sup>1</sup>Institute of Fundamental Technological Research, Pawinskiego 5B, 02-106 Warsaw, Poland  
e-mail: [bblach@ippt.pan.pl](mailto:bblach@ippt.pan.pl)

<sup>2</sup>Department of Civil Engineering, State Key Laboratory of Coastal and Offshore Engineering, Dalian University of Technology, Dalian, China

<sup>3</sup>Department of Civil and Environmental Engineering, University of Illinois at Urbana-Champaign, Urbana, Illinois, USA

## Abstract

The purpose of this study is to introduce a new method of damage quantification for truss structures. Its advantage is that it can be directly applied to engineering structures without identifying modal parameters or solving a global optimization problem. The damage is localized and quantified based only on measured acceleration signals, distributed across the structure. Moreover, the method is implemented in a decentralized way rather than a centralized one; that is, for quantification of damage in a given substructure, only a small subset of sensors is considered. The method possesses higher sensitivity to damage than other frequently used methods such as Damage Locating Vectors. Validation of the method has been conducted on a numerical example and a laboratory-scale model of a truss bridge, showing its efficiency and robustness.

## 1 Introduction

In the past two decades many papers concerning damage detection and structural health monitoring have been published [1-3]. Among them vibration-based methods have gained significant popularity [4]. However, in the case of truss structures, the current methods mostly deal with damage localization [5]; those designed for damage quantification are computationally very intensive [6].

Damage detection methods for truss structures can be classified as either modal or non-modal parameter based methods. An overview of the modal methods for damage detection can be found in the paper by Uhl and Mendrok [7]. The simplest modal methods assume that the occurrence of damage will cause a significant difference in natural frequencies of the structure [8, 9]. The more sophisticated modal methods take into account modification of mode shapes. In the paper by Lim et al. [10], a concept of best achievable eigenvectors has been presented. This concept is based on a projection of the measured mode shapes onto a subspace of undamaged modes. Then, the Euclidean distance between two sets of modal vectors is used for damage localization. Xu and Wu in their paper [11] proposed use of the first strain mode instead of the displacement mode for damage localization and quantification in a spatial truss structure.

Another group of modal methods use identified mode shapes to determine the flexibility matrix [12, 13]. Unfortunately, such an approach suffers from inaccuracy in modal identification and modal truncation. It was shown by Gao et al. [14] that only a few mode shapes can give a good approximation of the flexibility matrix in terms of the Frobenius norm. One should notice, however, that the comparison of approximated

and exact flexibility matrices which are close to each other in the sense of the Frobenius norm might not be sufficiently precise for damage detection. Moreover, the modal methods based on change in flexibility matrix before and after damage, such as Damage Locating Vectors, require determination of the null space of experimentally obtained matrices, which can be a very challenging task [15, 16].

Even if one overcomes the above mentioned difficulties, there is still one fundamental uncertainty which causes trouble in applying any of the modal methods. This issue is the lack of sensitivity of certain modal parameters to damage. It was shown by Blachowski et al. [17] that some natural frequencies and mode shapes in frame structures can be insensitive to damage introduced in its connections.

The above facts led many researchers to look for methods which do not require identification of modal parameters of the structure. The statistical series method by Kopsaftopoulos and Fassois [18] or Direct soft parametric identification (DSPI) by Xu et al. [19] are examples. The effectiveness of a non-modal method called Degree of Dispersion Damage Localization has been presented by An et al. [20] and validated for a laboratory-scale beam structure. In the paper by Blachowski and Gutkowski [21], the influence of a damaged substructure on the dynamic behavior of a truss structure has been demonstrated.

The purpose of this study is to introduce a new method of damage quantification. Its advantage over existing techniques is that it can be directly applied to engineering structures without the need of identifying modal parameters or solving a global optimization problem. The damage is localized and quantified based only on measured acceleration signals distributed across the structure. Moreover, the method is implemented in a decentralized manner, which means that for quantification of damage in a given substructure, only a small subset of sensors is considered. The method is characterized by higher sensitivity to damage than other frequently used methods such as Damage Locating Vectors. Validation of the method has been conducted on a numerical example and a laboratory-scale model of a truss bridge, showing its efficiency and robustness. The paper is organized as follows: the next section presents the theoretical background of the method; then the third section demonstrates results of a numerical simulation; and finally a summary and enumeration of the most important aspects of the method are given.

## 2 Proposed method

### 2.1 Theoretical background

The basic idea of the paper is based on the fact that in statically determinate structures, internal forces depend only on the configuration of the structure. This brings us to the observation that in a damaged structure, only the elements with reduced stiffness will have a modified response, while the other “healthy” members will preserve their dynamic behavior. We therefore first assume that selected accelerations are available for measurement. If so, we collect the accelerations of selected nodes in two orthogonal directions (Figure 1).

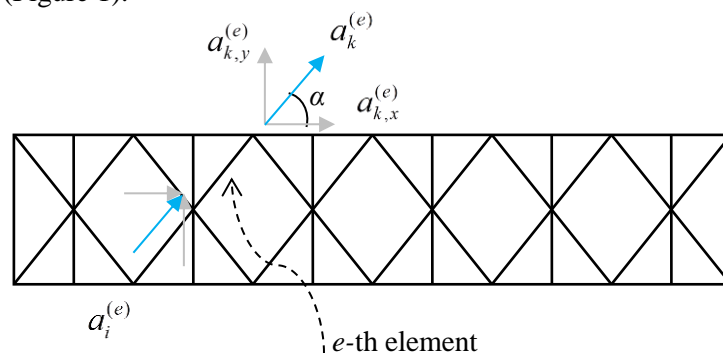

Figure 1: Measured quantities for damage detection in the  $e$ -th bar of the truss.

The internal forces in the  $e$ -th member of the truss for the healthy and damaged structures can be determined using the following formula

$$S^{(e)} = \frac{EA^{(e)}}{l^{(e)}} (q_k^{(e)} - q_i^{(e)}) \quad (1)$$

where  $E$  is Young modulus,  $A^{(e)}$  is cross section area,  $l^{(e)}$  is length of the member,  $q_k^{(e)}$  and  $q_i^{(e)}$  are nodal displacements of the member's ends.

Keeping in mind that we perform a dynamic analysis, we write equation (1) at every time instant  $t_j$ ,

$$S_j^{(e)} = \frac{EA^{(e)}}{l^{(e)}} (q_{k,j}^{(e)} - q_{i,j}^{(e)}) \quad (2)$$

where  $j=1,2,\dots,n_T$  and  $n_T$  denotes the number of time instances.

In the formula (2) we are using displacements for determining the internal forces. However, from the practical point of view, it is much more convenient to measure accelerations instead of displacements. Then, instead of forces we will be talking about their second derivatives with respect to time

$$\ddot{S}_j^{(e)} = \frac{EA^{(e)}}{l^{(e)}} (\ddot{q}_{k,j}^{(e)} - \ddot{q}_{i,j}^{(e)}) = \frac{EA^{(e)}}{l^{(e)}} (a_{k,j}^{(e)} - a_{i,j}^{(e)}) \quad (3)$$

The right-hand side term of equation (3) will be called 'axial strain accelerations', which is defined as a difference of ends accelerations for a given structural member, namely

$$\mathcal{E}_{a,j}^{(e)} = a_{k,j}^{(e)} - a_{i,j}^{(e)} \quad (4)$$

Now, we are applying the well-known fact that in statically determinate structures internal forces do not depend on their cross sectional areas. In a static analysis for the same loading, the internal forces will be the same regardless of the choice of cross section areas for given members. In the dynamic analysis, instead of the value of force at a single time instant we will be using the Root Mean Square (RMS) of the force accelerations

$$\ddot{S}_{RMS}^{(e)} = \sqrt{\frac{1}{n_T} \sum_{j=1}^{n_T} \ddot{S}_j^{(e)2}} \quad (5)$$

Next, we distinguish between undamaged and damaged RMS of force accelerations,  $\hat{\ddot{S}}_{RMS}^{(e)}$  and  $\tilde{\ddot{S}}_{RMS}^{(e)}$ , respectively.

Having determined RMS of force accelerations for both cases we expect that they will be equal for a sufficiently long realization. So, we will write

$$\hat{\ddot{S}}_{RMS}^{(e)} \cong \tilde{\ddot{S}}_{RMS}^{(e)} \quad (6)$$

Substituting (3) into (6) we can write the relation between axial strain accelerations for healthy and damaged structures as

$$\hat{K}^{(e)} \hat{\mathcal{E}}_{a,RMS}^{(e)} = \tilde{K}^{(e)} \tilde{\mathcal{E}}_{a,RMS}^{(e)} \quad (7)$$

where  $\hat{\mathcal{E}}_{a,RMS}^{(e)}$ ,  $\tilde{\mathcal{E}}_{a,RMS}^{(e)}$  are RMS of axial strain accelerations of the  $e$ -th member for undamaged and damaged structure, and  $\hat{K}^{(e)}$ ,  $\tilde{K}^{(e)}$  are its axial stiffnesses (i.e.  $EA^{(e)}$ ,  $E$  and  $A^{(e)}$  are elastic modulus and cross sectional areas) of an undamaged and damaged element, respectively.

## 2.2 Damage quantification approaches

### 2.2.1 Damage quantification for the case of a given initial state

For the case when the initial state of the structure is known or measured we can quantify damage in the structure using directly equation (7).

RMS of axial strain accelerations  $\hat{\varepsilon}_{a,RMS}^{(e)}$  and  $\tilde{\varepsilon}_{a,RMS}^{(e)}$  are available from measurements. Assuming that in the damaged case stiffness of a given member is reduced by a certain value  $\Delta K^{(e)}$  we can write equation (7) in the following form

$$\hat{K}^{(e)} \hat{\varepsilon}_{a,RMS}^{(e)} = (\hat{K}^{(e)} - \Delta K^{(e)}) \tilde{\varepsilon}_{a,RMS}^{(e)} \quad (8)$$

From equation (8), we can determine the relative difference in stiffnesses before and after damage as follows

$$\Delta K^{(e)} / \hat{K}^{(e)} = (\tilde{\varepsilon}_{a,RMS}^{(e)} - \hat{\varepsilon}_{a,RMS}^{(e)}) / \tilde{\varepsilon}_{a,RMS}^{(e)} \quad (9)$$

This simple, yet important, formula tells us that reduction of the stiffness in damaged elements is proportional to the ratio of the difference of the RMS of axial strain accelerations before and after damage to the RMS of axial strain acceleration of the damaged member.

### 2.2.2 Damage quantification for the case of an unknown initial state

In the case of an unknown initial (undamaged) condition of the truss, one can use any of the identification procedures available in the literature. An alternative approach could rely on using an FE model as a reference (undamaged) condition. This issue will be the topic of further investigations.

## 3 Numerical simulation

### 3.1 Truss structure under investigation

In the present study the 14-bay planar truss shown in Figure 2 is considered. The truss is attached to two rigid supports. One end of the truss is pinned to the support and the other is roller-supported. The pinned end can rotate freely with all two translations restricted. The roller end can move in the longitudinal direction.

This planar truss consists of 53 circular steel bars, which have an inner diameter of 1.09 cm and an outer diameter of 1.71 cm. The resulting cross sectional area is equal to  $1.122 \times 10^{-4} \text{ m}^2$  and an area moment of inertia equals  $2.111 \times 10^{-9} \text{ m}^4$ . The elastic modulus of the material is  $2 \times 10^{11} \text{ N/m}^2$ , and the mass density is  $7.83 \times 10^3 \text{ kg/m}^3$ . The total length of this truss is 5.6 m, with each bay being 0.4 m x 0.4 m.

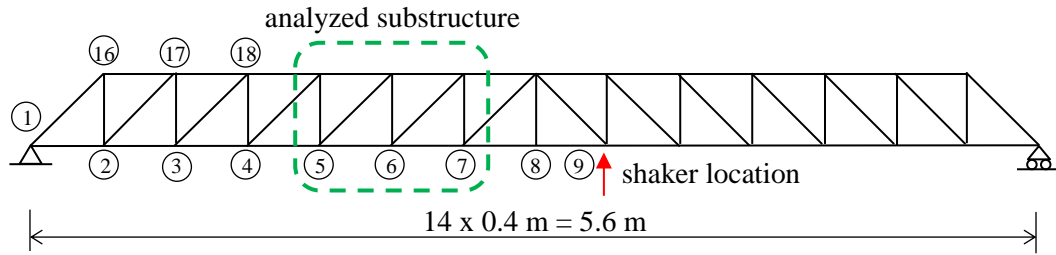

Figure 2: Planar truss selected for this study.

A finite element model consisting of 53 bars and 28 nodes has been developed in Matlab. A two-dimensional frame finite element has been used for individual bars. The connections between truss bars are assumed to be rigid.

The truss is excited vertically by a shaker that generates a maximum force of 15 N (Figure 3). A band-limited white noise is sent to the shaker to excite the structure up to 200 Hz.

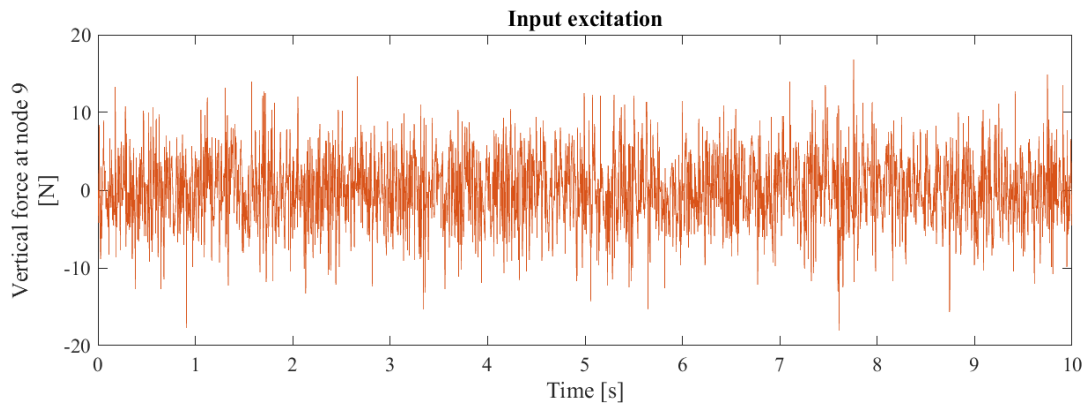

Figure 3: Input excitation applied to the system.

In the present study a limited number of sensors is used to monitor members of a selected substructure (Figure 2). The 9 elements of the substructure, which are elements no. 15 through 23, are monitored using 6 two-directional accelerometers, measuring acceleration in two orthogonal directions (Figure 6).

An example of acceleration signals obtained at node 7 is shown in Figures 4 and 5.

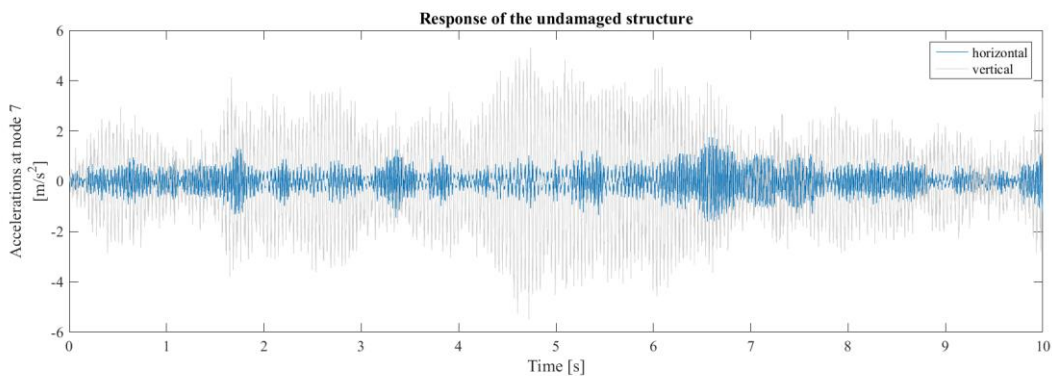

Figure 4: Response of the undamaged structure.

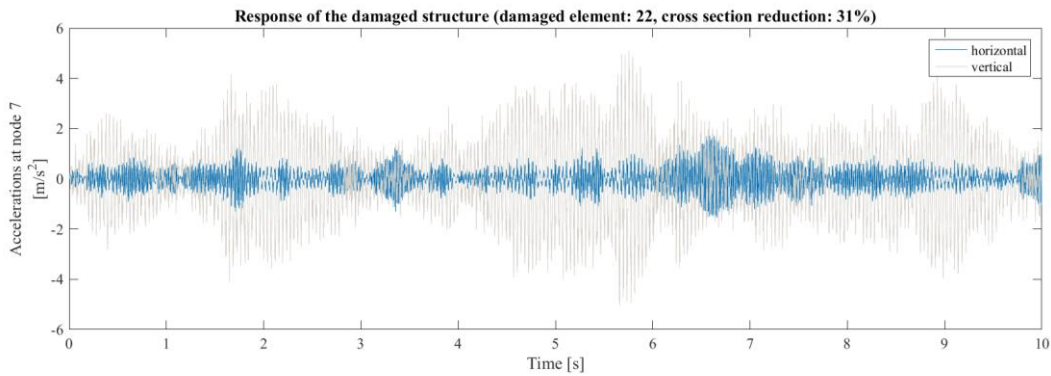

Figure 5: Response of the damaged structure.

Based on the FE model of the truss, a Simulink model of the whole dynamic system has been developed including random excitation and signal processing techniques (Figure 6). Eight-pole elliptical anti-aliasing filters are employed for both the input and the output measurements with a cutoff frequency of 200 Hz. The sampling rate for all measurements is 512 Hz.

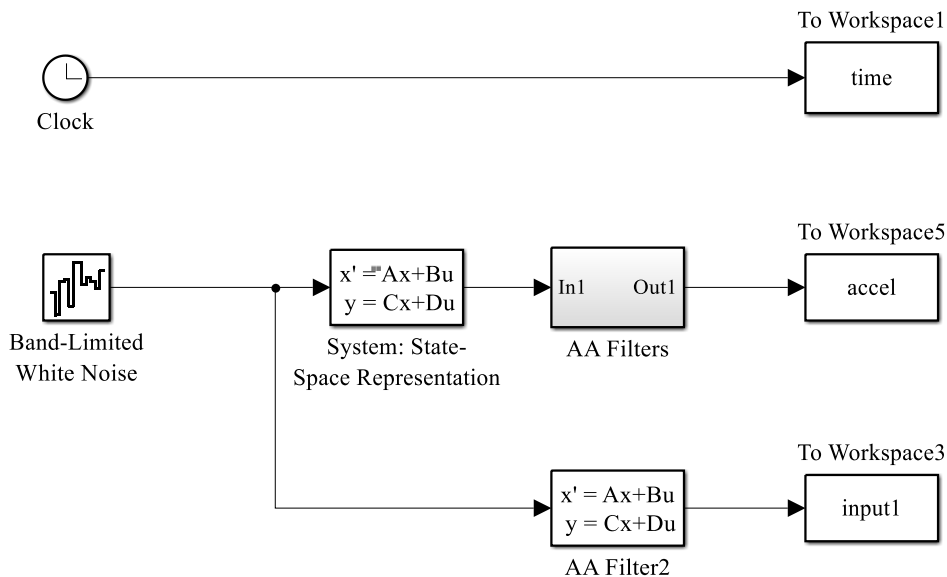

Figure 6: Simulink model of the structure under investigation.

### 3.2 Assumed damage scenarios

Different groups of damage scenarios have been studied. In the first group of scenarios, there is only one damaged member and its damage is simulated by replacing the original member with one having a 25% smaller Young modulus. The second group consists of scenarios related to multiple damaged members also with stiffness reduced by 25%. Measurements for both groups of damage scenarios are corrupted by noise, however one can reduce noise by applying several times excitation with the same time history and then averaging the responses over the realizations.

Detailed information about the analyzed damage scenarios is presented in Table 1 and Figure 7.

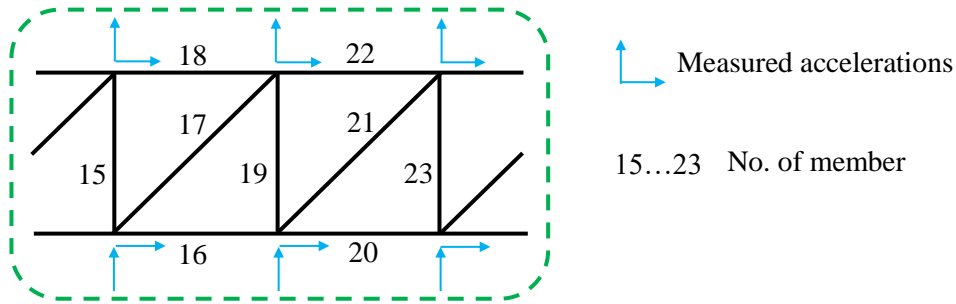

Figure 7: Number of elements within the selected substructure.

Damage scenario		No. of member	Damage severity
Single damage	1. vertical member	15	25%
	2. diagonal member	21	25%
	3. horizontal member	22	25%
Multiple damage	4. three damaged members	16, 19, 23	25%

Table 1: Analyzed damage scenarios

### 3.3 Damage quantification using the proposed method

In this section the results of the damage quantification using the proposed method are shown. In Figures 8-11 a comparison of the real (applied) damage and identified damage is presented graphically. One can observe a good agreement between those two. However, some discrepancy is evident, especially for the horizontal members: element 22 in damage scenario no. 3. This discrepancy indicates the fact that the rotational stiffness of joints in horizontal members has a greater influence on the assumption of statically determinate structures.

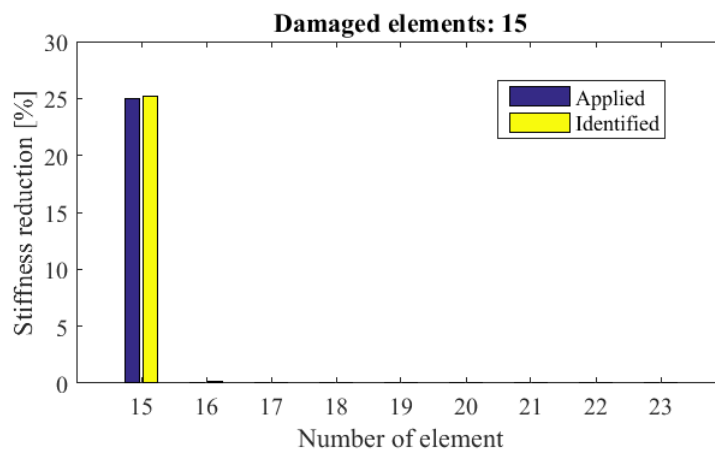

Figure 8: Damage scenario no. 1 – vertical element

In vertical and diagonal members the discrepancy is smaller and the accuracy of identification could be accepted from the engineering point of view.

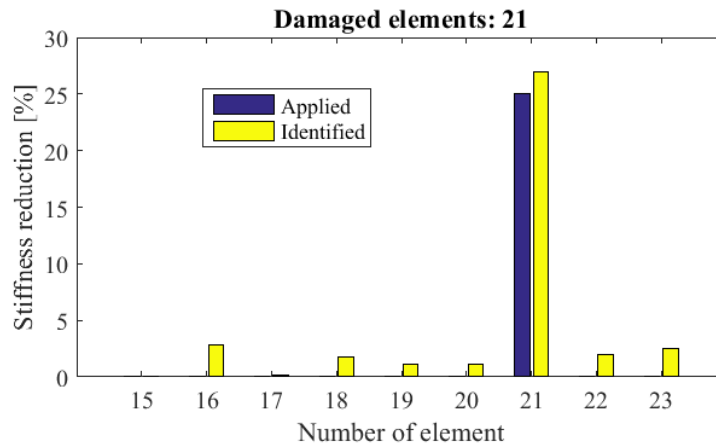

Figure 9: Damage scenario no. 2 – diagonal element

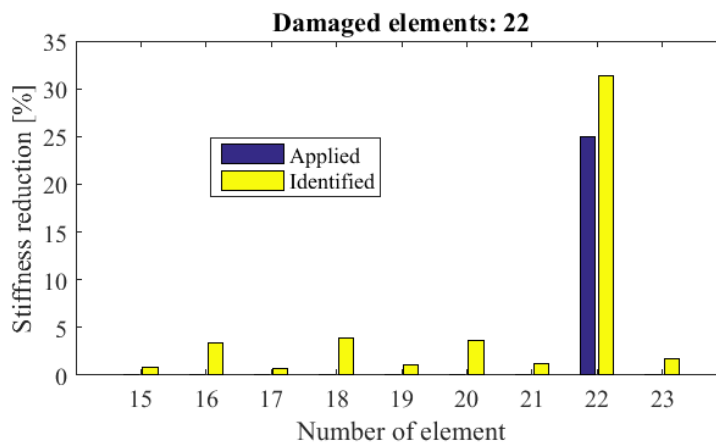

Figure 10: Damage scenario no. 3 – horizontal element

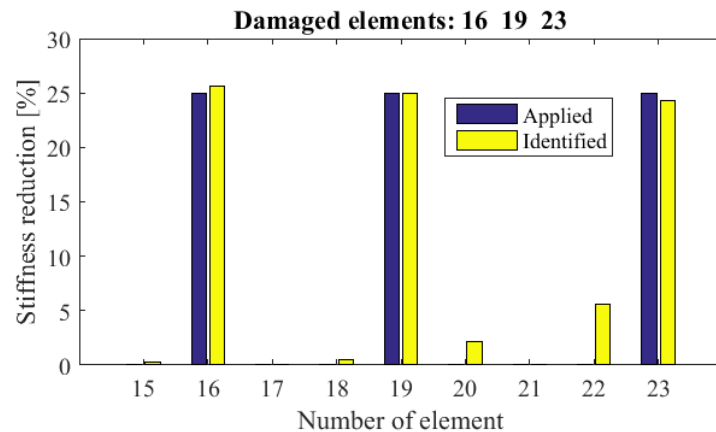

Figure 11: Damage scenario no. 4 – multiple damaged elements

### 3.4 Influence of noise on damage quantification accuracy

Real measurements are always corrupted by noise, so it is important that the proposed damage detection method be robust under noisy measurement. In the Figs. 12-13 the influence of noise on the accuracy of damage quantification is presented. The damage scenario assumed that all three members 17, 19 and 21 have Young modulus reduced by 25% and measurements are corrupted with 5% noise. It is evident that noise has a negative influence on damage quantification, but even for 5% of measurement noise the results of damage assessment would be acceptable from practical point of view.



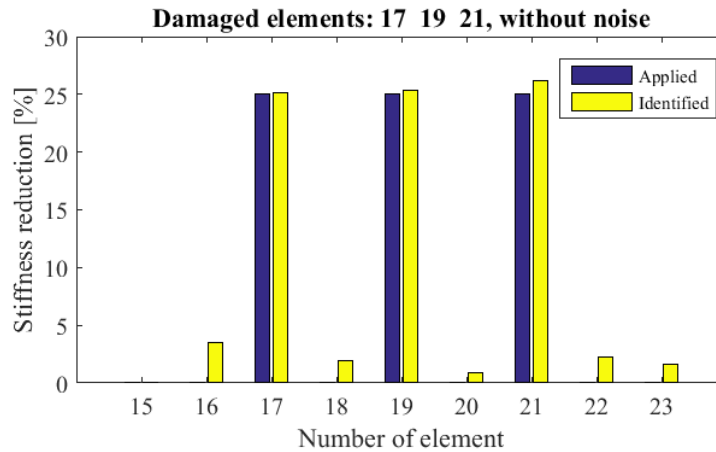

Figure 12: Damage quantification without noise corrupted measurements

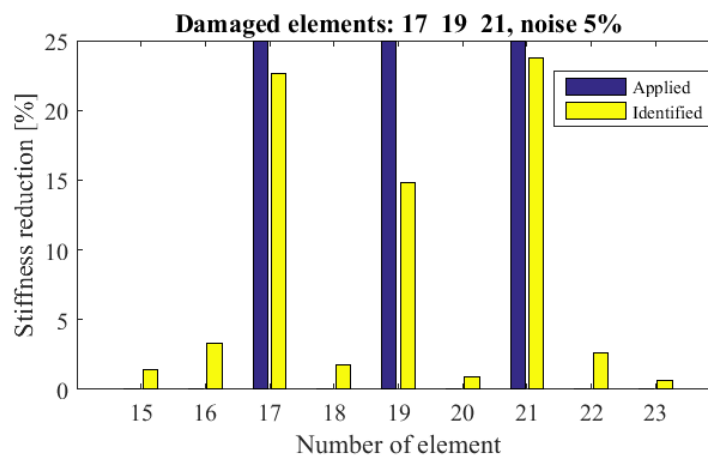

Figure 13: Damage quantification in presence 5% noise.

## 4 Conclusions

In the paper a simple and efficient technique for damage localization in statically determinant truss structures has been presented. The method is based on axial strain accelerations calculated directly from measured accelerations with ambient excitation. The proposed damage quantification method can be summarized as follows:

- (1) All numerical tests conducted indicate that the proposed method can be successfully used in real-time damage monitoring of statically determinant truss structures.
- (2) The advantage of the proposed method is the fact that it does not require any sophisticated matrix operations such as Singular Value Decomposition (SVD), Triangular orthogonal decomposition or even Eigenvalue analysis.
- (3) The proposed damage quantification method works under ambient excitation such as traffic excitation, wind excitation, and so on. Therefore, it is very attractive for real-time structural health monitoring of truss structures.
- (4) The severity of damage is determined in a straightforward way.

All of these lay a good foundation for the engineering application of the method.

## Acknowledgements

The first author would like to express his gratitude for financial support from the Polish Ministry of Science and Higher Education, program “Mobility Plus” no. MNiSW, 634/MOB/2011/0.

## References

- [1] S.W. Doebling, Ch.R. Farrar, M.B. Prime, D.W. Shevitz, *Damage identification and health monitoring of structural and mechanical systems from changes in their vibration characteristics: A literature review*, Los Alamos National Laboratory Report, LA-13070-MS, UC-900, Issued: May (1996).
- [2] J.J. Sinou, *A review of damage detection and health monitoring of mechanical systems from changes in the measurement of linear and non-linear vibrations*, in Robert C. Sapri, *Mechanical Vibrations: Measurement, Effects and Control*, Nova Science Publishers (2009), pp.643-702.
- [3] W. Ostachowicz, A. Güemes: editors, *New Trends in Structural Health Monitoring*, CISM, Udine, Italy, Springer (2013).
- [4] A. Deraemaeker, K. Worden: editors, *New Trends in Vibration Based Structural Health Monitoring*, CISM, Udine, Italy, Springer (2010).
- [5] D. Bernal, *Flexibility-based damage localization from stochastic realization results*, Journal of Engineering Mechanics, Vol. 132, No. 6, American Society of Civil Engineers (2006), pp.651-658.
- [6] R.A. Osornio-Rios, J.P. Amezcua-Sanchez, R.J. Romero-Troncoso, A. Garcia-Perez, *MUSIC-ANN Analysis for Locating Structural Damages in a Truss-Type Structure by Means of Vibrations*, Computer-Aided Civil and Infrastructure Engineering 27, Wiley (2012), pp.687-698.
- [7] T. Uhl, K. Mendrok, *Overview of modal model based damage detection methods*, *Proceedings of International Conference on Noise and Vibration Engineering (ISMA2004)*, Leuven, 20-22 September 2004, pp.561-576.
- [8] L. Wang, T.H.T. Chan, D.P. Thambiratnam, A.C.C. Tan, *Damage detection for truss bridge structures using correlation-based structural modal strain energy*, *Proceedings of 8th International Conference on Short and Medium Span Bridges*, Niagara Falls, Canada 2010, pp.143-1 - 143-11.
- [9] N.I. Kim, H. Kim, J. Lee, *Damage detection of truss structures using two-stage optimization based on micro genetic algorithm*, Journal of Mechanical Science and Technology 28(9), Springer (2014), pp.3687-3695.
- [10] T.W. Lim, T.A.L. Kashangaki, *Structural damage detection of space truss structures using best achievable eigenvectors*, AIAA Journal, Vol. 32, No. 5, The American Institute of Aeronautics and Astronautics (1994), pp. 1049-1057.
- [11] Z.D. Xu, K.Y. Wu, *Damage detection for space truss structures based on strain mode under ambient excitation*, Journal of Engineering Mechanics Vol. 138, No. 10, American Society of Civil Engineers (2012), pp.1215-1223.
- [12] M. Montazer, S.M. Seyedpoor, *A new flexibility based damage index for damage detection of truss structures*, Shock and Vibration, Vol. 2014, Article ID 460692, Hindawi Publishing Corporation (2014), 12 pages.
- [13] S.M. Seyedpoor, M. Montazer, *A damage identification method for truss structures using a flexibility-based damage probability index and differential evolution algorithm*, Inverse Problems in Science and Engineering, Published online: 29 Oct 2015, DOI:10.1080/17415977.2015.1101761, Taylor & Francis (2015), 20 pages.

- [14] Y. Gao, B. Spencer Jr., D. Bernal, *Experimental Verification of the Flexibility-Based Damage Locating Vector Method*, Journal of Engineering Mechanics, Vol.133, Issue 10, American Society of Civil Engineers (2007), pp.1043-1049.
- [15] Y. An, B. Blachowski, J. Ou, *Numerical study on  $LDL^T$  decomposition-based damage locating vector method for truss structures*, Proceedings of the Second International Conference on Performance-based and Life-cycle Structural Engineering (PLSE 2015), 9-11 December, Brisbane, Australia (2015), pp. 256-260.
- [16] Y. An, B. Blachowski, Y. Zhong, P. Holobut, J. Ou, *Rank-revealing QR decomposition applied to damage localization in truss structures*, Structural Control and Health Monitoring, Wiley (2016), DOI: 10.1002/stc.1849, Article first published online: 18 FEB 2016.
- [17] B. Blachowski, A. Swiercz, P. Gutkiewicz, J. Szelazek, W. Gutkowski, *Structural damage detectability using modal and ultrasonic approaches*, Measurement, Volume 85, Elsevier (2016), pp. 210-221.
- [18] F.P. Kopsaftopoulos, S.D. Fassois, *Vibration based health monitoring for a lightweight truss structure: experimental assessment of several statistical time series methods*, Proceedings of International Conference on Noise and Vibration Engineering (ISMA2010-USD2010), Leuven, 20-22 September 2010, pp.867-892.
- [19] B. Xu, G. Chen, Z.S. Wu, *Parametric identification for a truss structure using axial strain*, Computer-Aided Civil and Infrastructure Engineering 22, Wiley (2007), pp.210-222.
- [20] Y. An, B. Blachowski, J. Ou, *A degree of dispersion-based damage localization method*, Structural Control and Health Monitoring, Volume 23, Issue 1, Wiley (2016), pp. 176-192.
- [21] B. Blachowski, W. Gutkowski, *Effect of damaged circular flange-bolted connections on behaviour of tall towers, modelled by multilevel substructuring*, Engineering Structures, Volume 111, Elsevier (2016), pp. 93-103.

